



# Radoroc

## Dual Read-Out (Photon Counting & Charge Integration) Multi-Purpose SiPM Analogue Read-out Chip

Radoroc 2 is a 64-channel front-end ASIC designed to readout silicon photo-multipliers (SiPM). Radoroc 2 allows triggering down to 1/3 p.e. and provides dual-gain energy measurement with excellent Signal-to-noise ratio on the high gain (SNR over 10 for single p.e.) and large dynamic range on the low gain.

Moreover, Radoroc 2 can output the 64-channel triggers with jitter as low as 55 ps FWHM on a single p.e. (160 fC,  $C_{inj} = 100\text{pF}$ ). Photon-counting has been measured to be over 200 MHz. Time Over Threshold (TOT) can be used and has been measured to be able to handle the full input swing.

An adjustment of the SiPM high-voltage is possible using a channel-by-channel 8-bit DAC connected to the ASIC inputs to homogenize SiPM gains.

Timing resolution better than 55 ps FWHM is possible along with 1% linearity energy measurement up to 2000 p.e. Outputs can be selected via I<sup>2</sup>C channel wise with 2 direct outputs per channel and the possibility to output single-ended/differential triggers or analog signals.

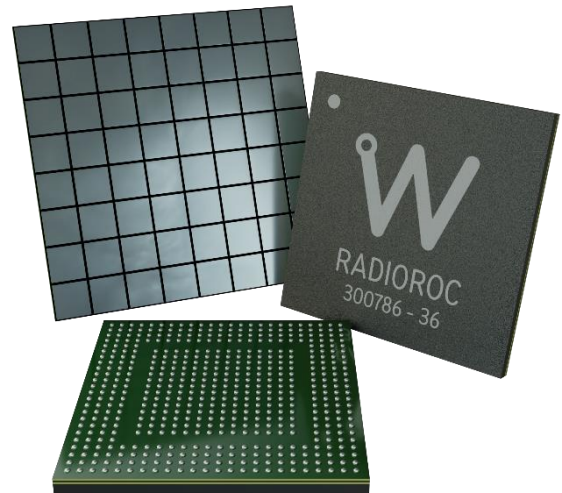

Detector Read-Out	SiPM, SiPM array
Number of Channels	64
Signal Polarity	Positive
Sensitivity	Trigger on 1/3 of photo-electron
Timing Resolution	55 ps FWHM on single photo-electron
Photon Counting	200 Mhz
Dynamic Range	Up to 2000 photo-electrons @ $10^6$ SiPM gain
Packaging & Dimension	BGA 20x20 mm <sup>2</sup>
Power Consumption	310mW – Supply voltage : 1.2 V
Inputs	64 analogue inputs with independent SiPM HV adjustments
Outputs	2 direct outputs per channel, selectable channel-per-channel, either: <ul style="list-style-type: none"> <li>• 1 LVDS triggers</li> <li>• 2 TTL triggers</li> <li>• 1 TTL triggers and 1 analog outputs</li> <li>• 2 analog outputs</li> </ul> 2 multiplexed analogue outputs and 3 NOR64 trigger outputs
Internal Programmable Features (I <sup>2</sup> C)	64 HV adjustment for SiPM (64 x 8 bits), 3 trigger threshold tuning (10bits), channel-by-channel gain and shaping time adjustment ( $\tau = 20\text{ ns to }1800\text{ ns}$ ), individual trigger masking and cell powering.

### More about Radoroc

<b>Contact</b>	Jean-Baptiste CIZEL
<b>Web</b>	<a href="https://www.weeroc.com/">https://www.weeroc.com/</a>
<b>Email</b>	<a href="mailto:jean-baptiste.cizel@weeroc.com">jean-baptiste.cizel@weeroc.com</a>
<b>Phone</b>	+33 1 85 41 13 90



weeroc

# Radioroc

Dual Read-Out (Photon Counting & Charge Integration)  
Multi-Purpose SiPM Analogue Read-out Chip

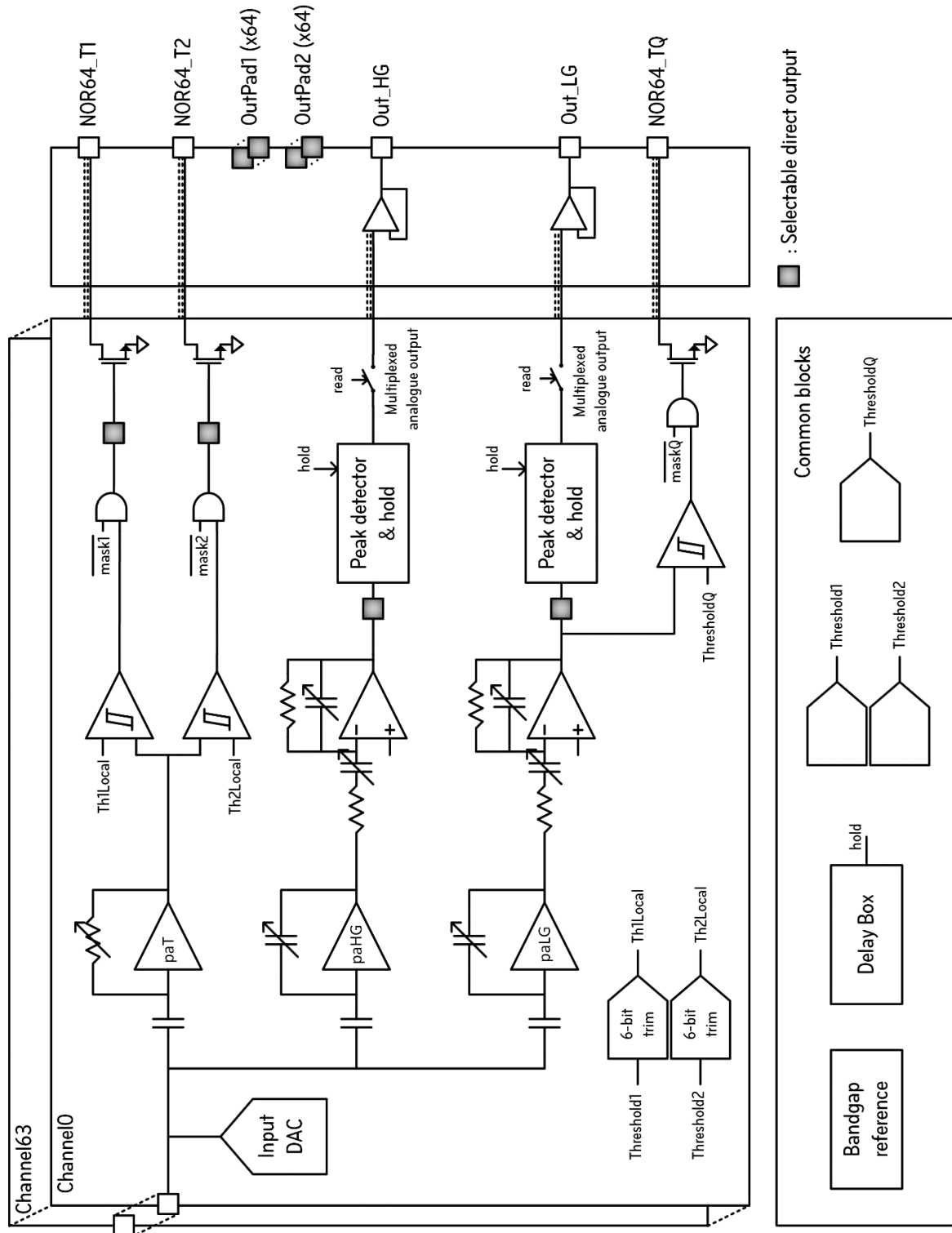

paT – Trigger preamplifier ; paHG – High Gain charge measurement preamplifier ; paLG – Low Gain charge measurement preamplifier.